

Operating Systems

Introduction to Lab 7 Synchronization and Mutex

Department of Computer Science & Technology
Tsinghua University
IIS



Outline

- ◆ Work Flow & Key Functions and Data Structures
- ◆ The Dining Philosophers Problem via Semaphore
- ◆ The Dining Philosophers Problem via Monitor

Work Flow & Key Functions and Data Structures

◆ Work Flow (Exercise 1 & 2)

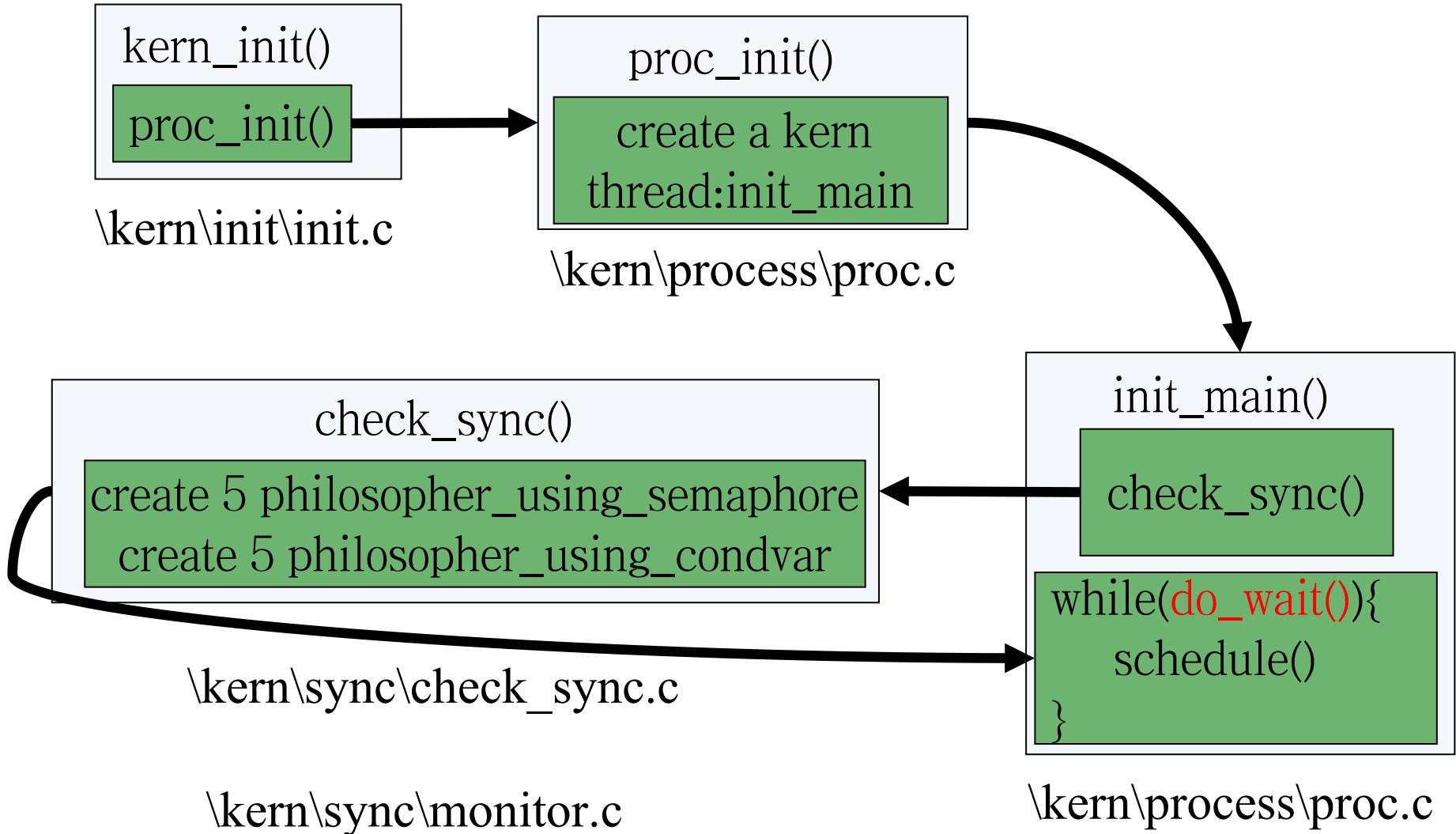

◆ Key Functions

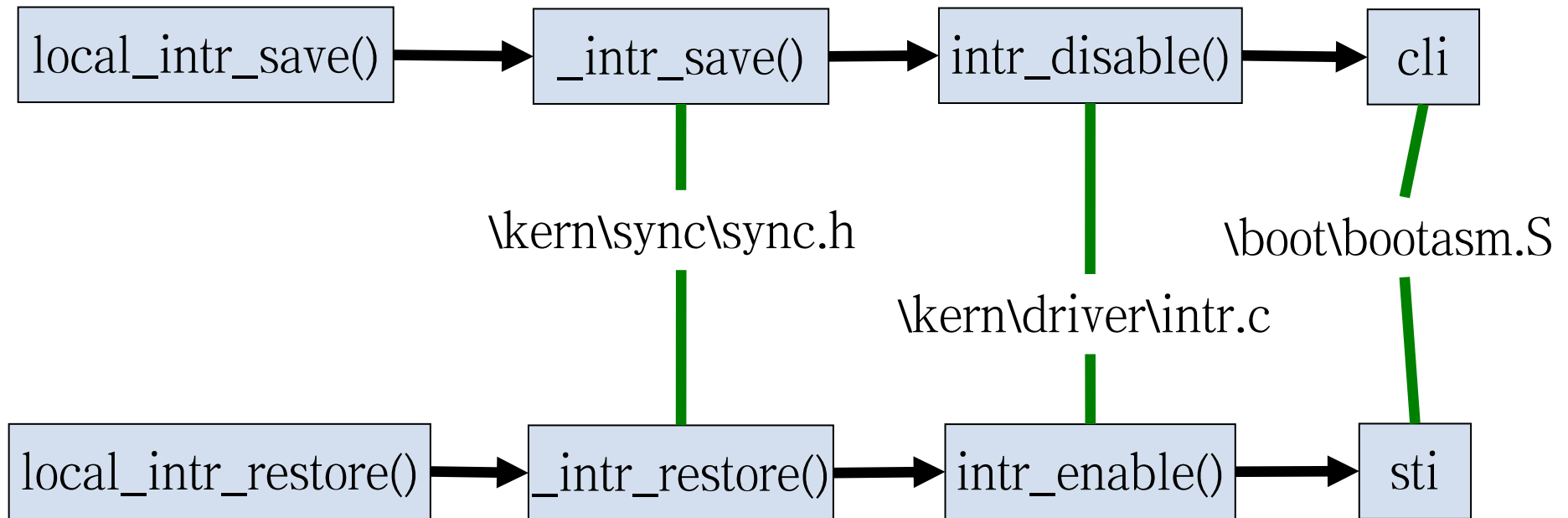

◆ Key Data Structures

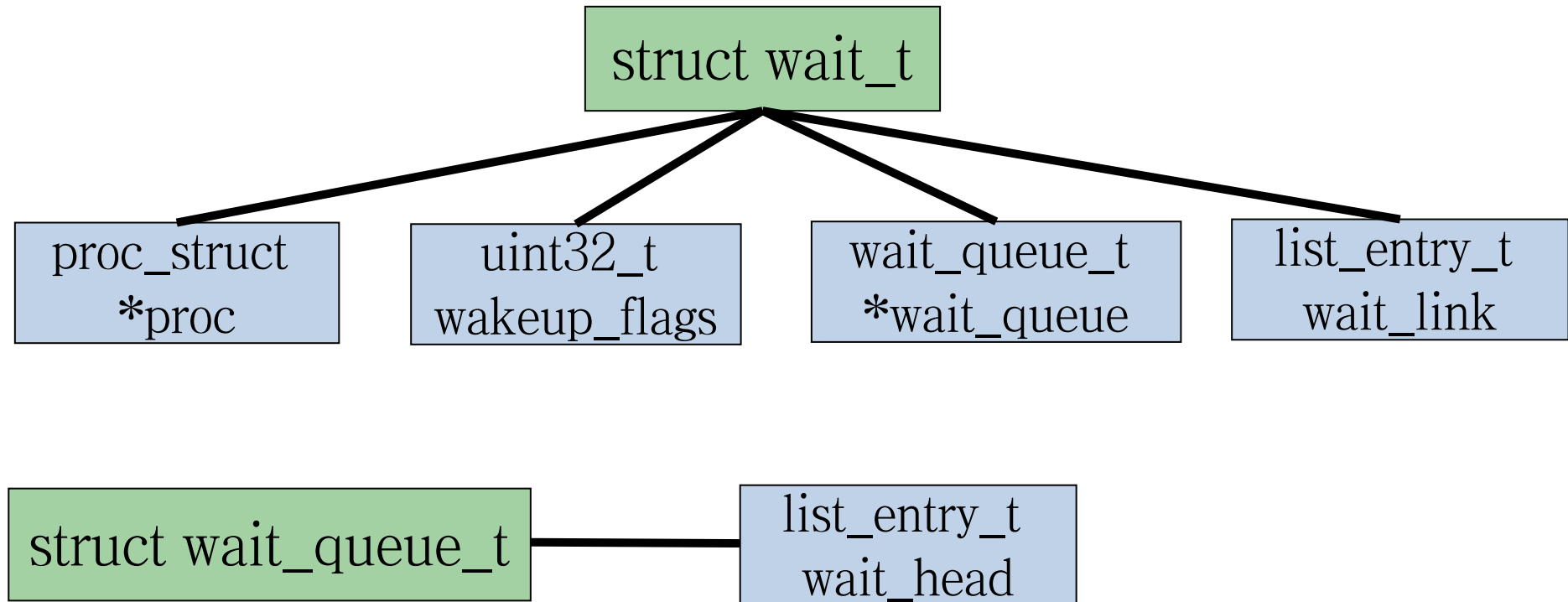

The Dining Philosophers Problem via *Semaphore*

- ◆ Semaphore Data Structure and Two Operations

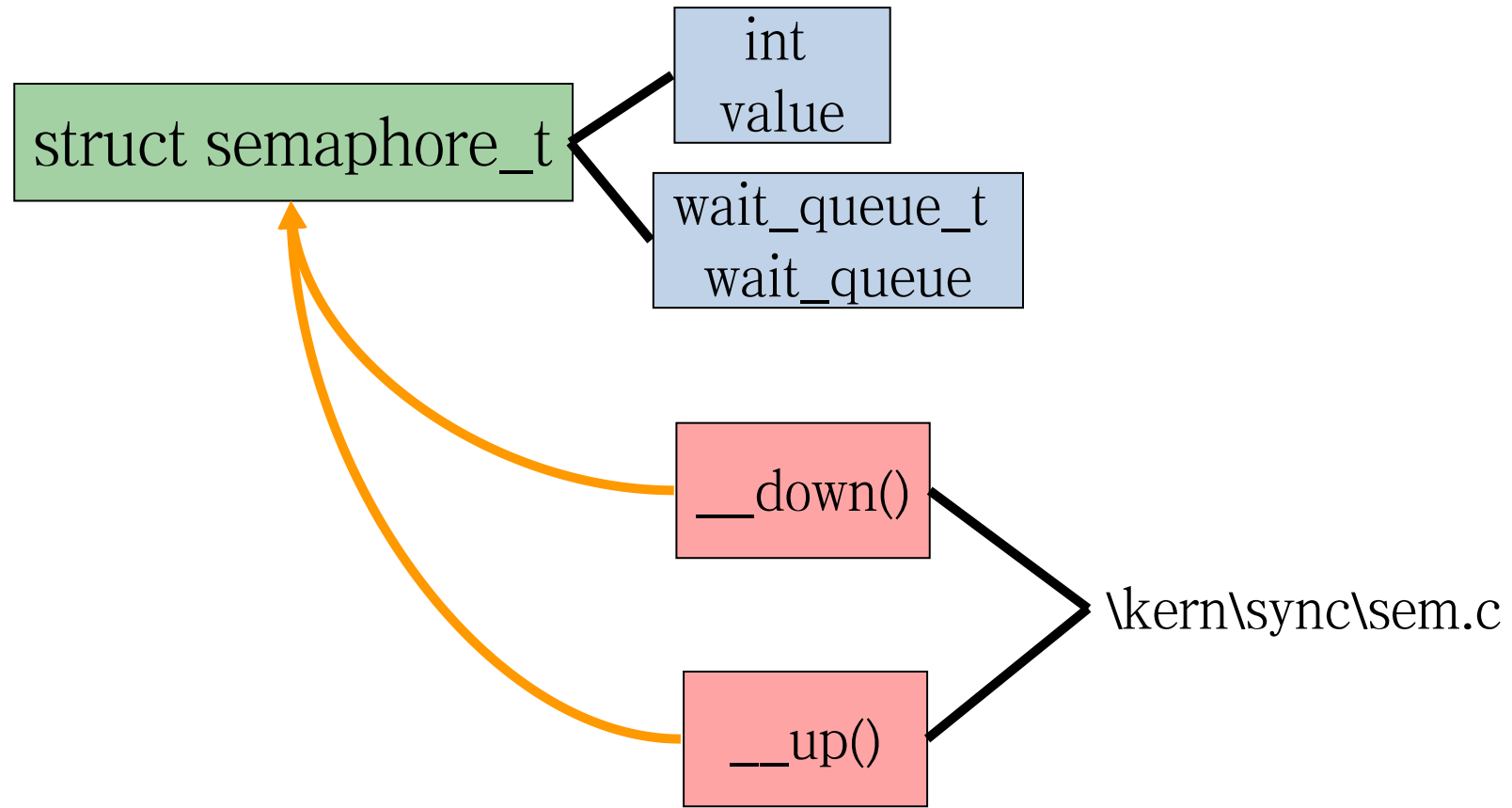

The Dining Philosophers Problem via *Semaphore*

◆ P operation: `__down()`

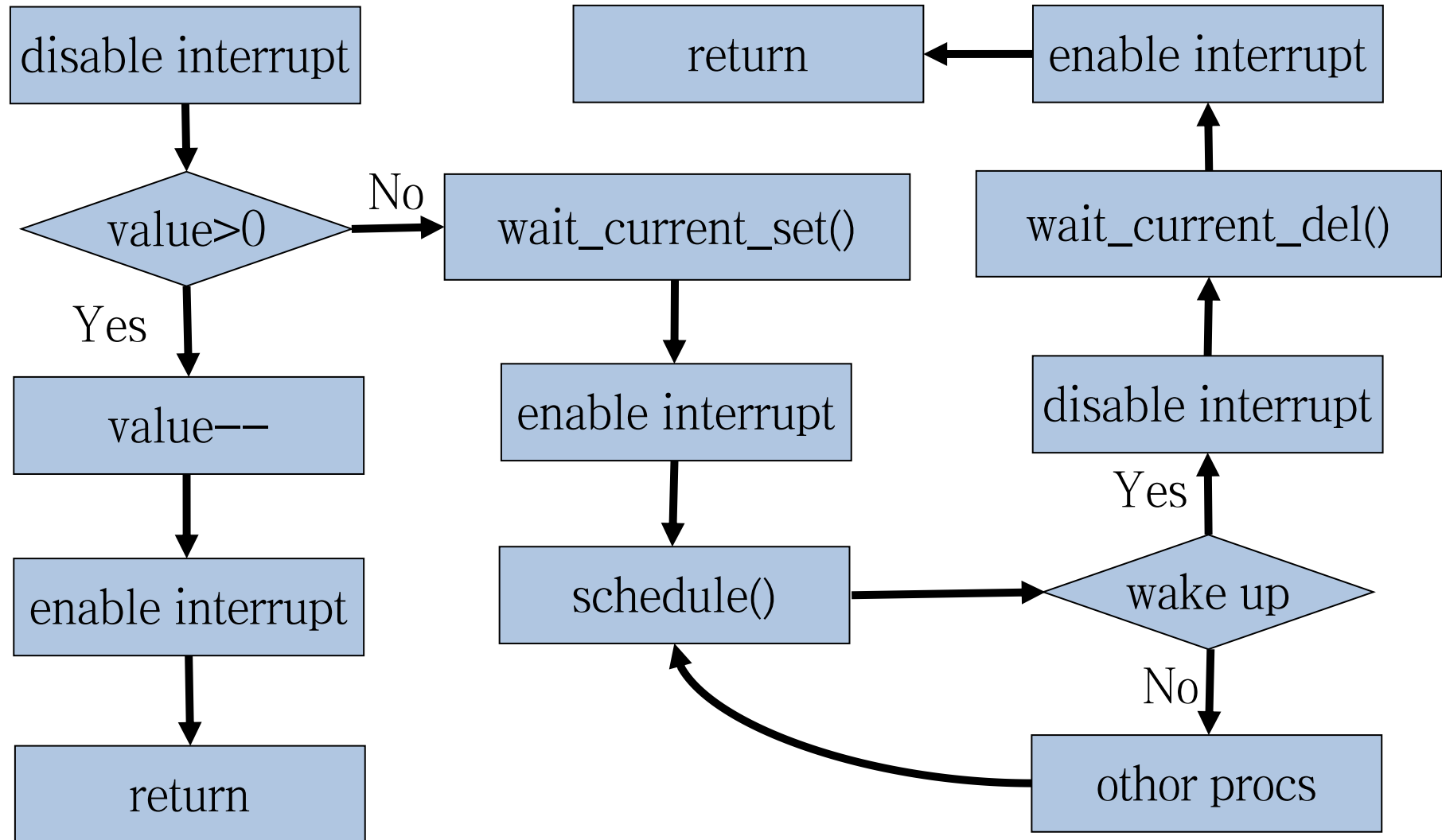

- ◆ V operation: `__up()`

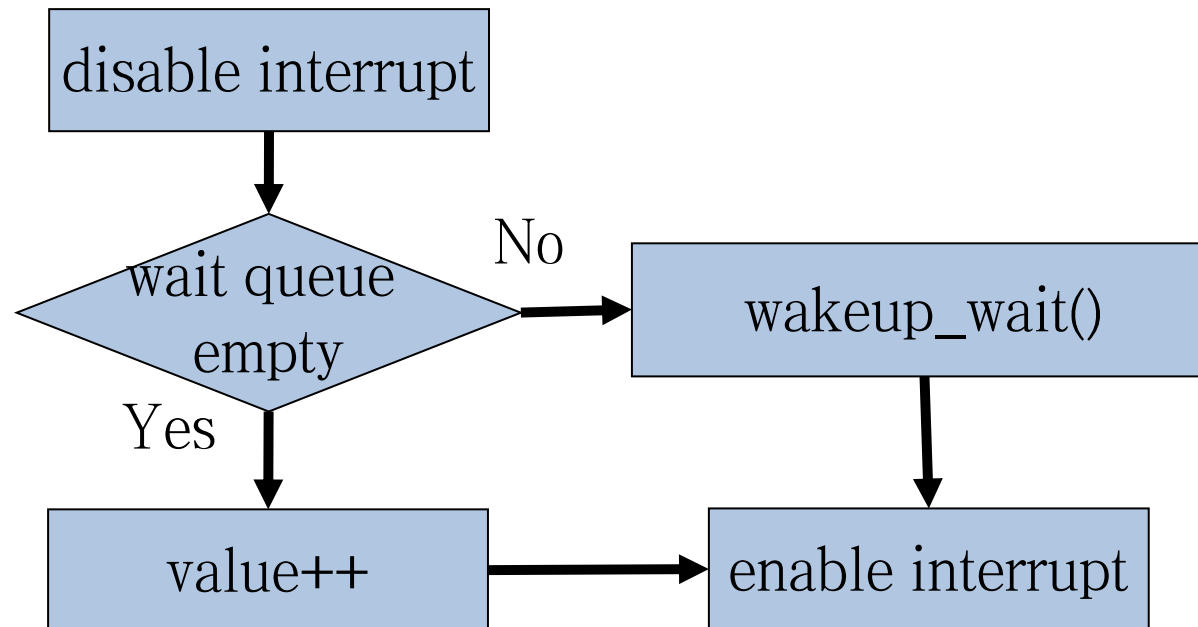

The Dining Philosophers Problem via *Monitor*

◆ Monitor Data Structures (\kern\sync\monitor.h)

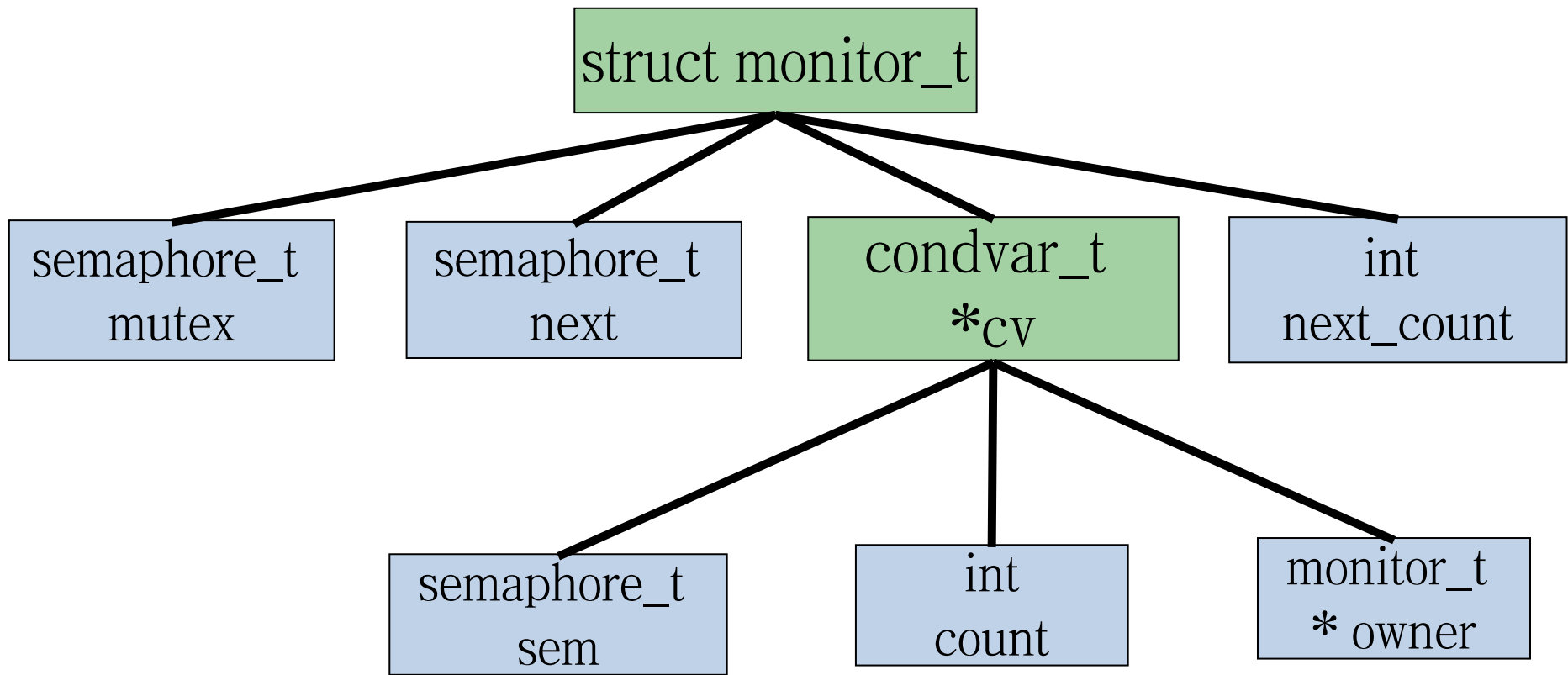

The Dining Philosophers Problem via *Semaphore*

◆ cond_wait() (\kern\sync\monitor.c)

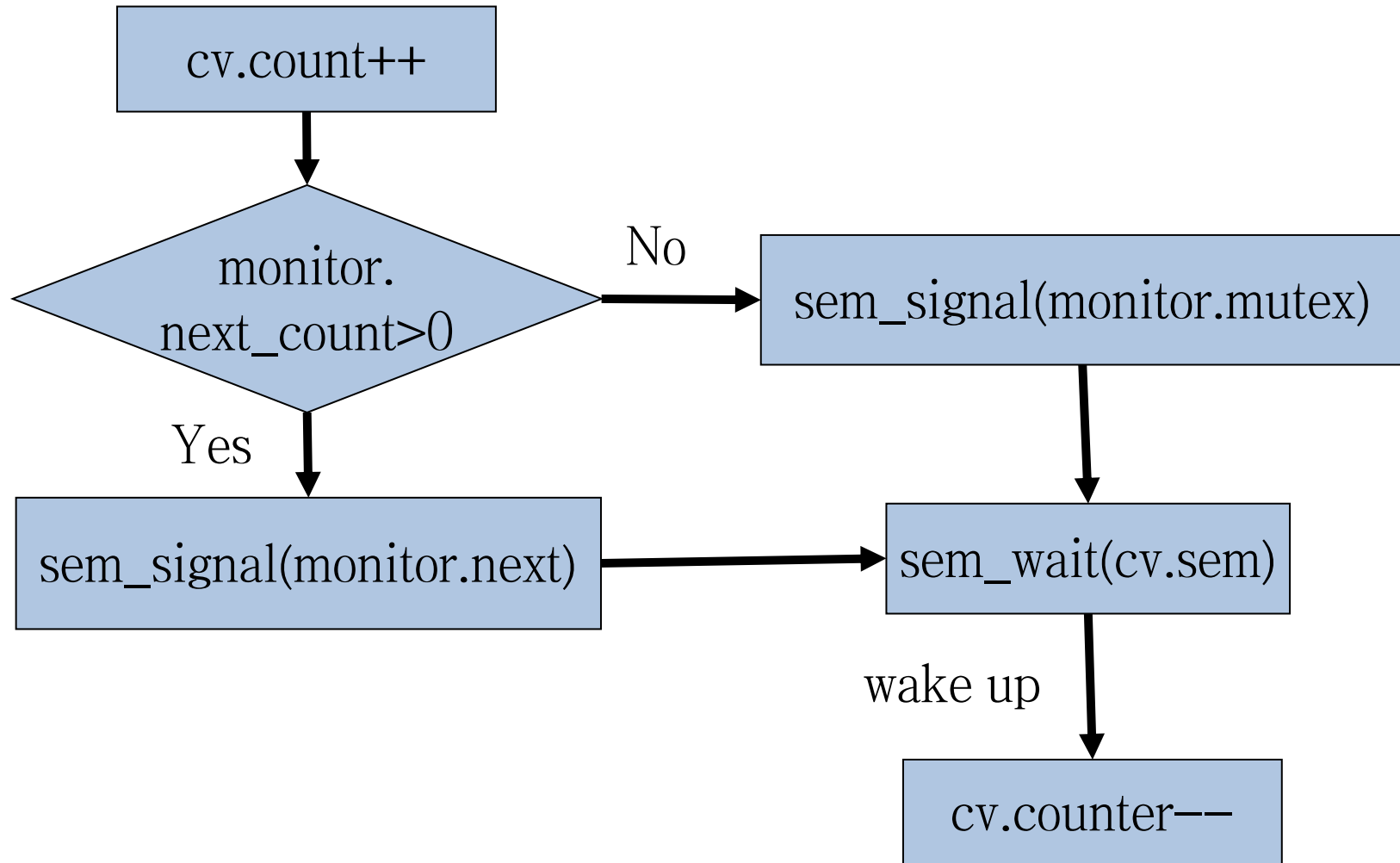

The Dining Philosophers Problem via *Semaphore*

◆ `cond_signal()` (`\kern\sync\monitor.c`)

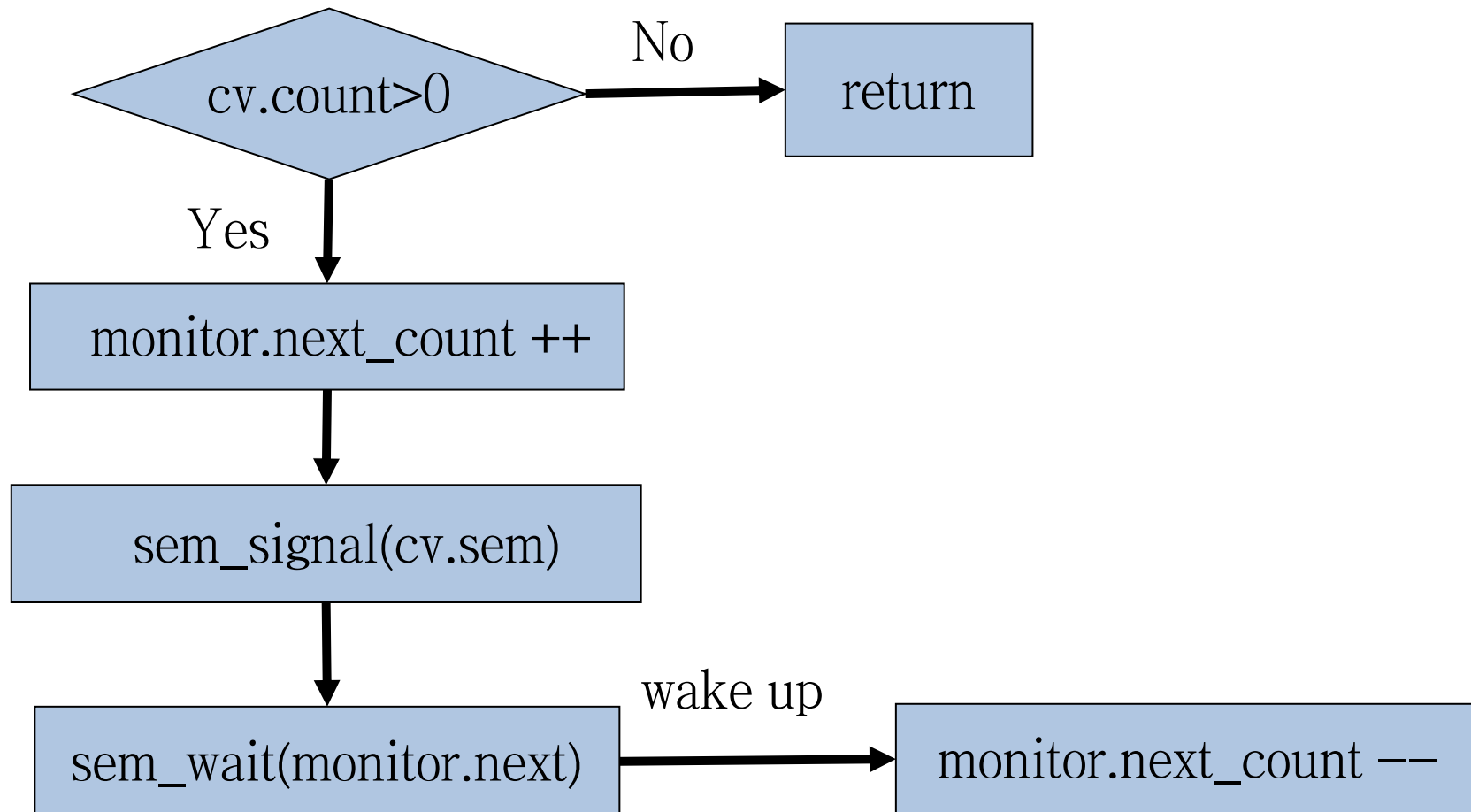

That's all. Thanks!